

**• General Description**

It combines advanced trench MOSFET technology with a low resistance package to provide extremely low  $R_{DS(ON)}$ .

**• Features**

- Advance device constructure
- Low  $R_{DS(ON)}$  to minimize conduction loss
- Low Gate Charge for fast switching
- Low Thermal resistance

**• Application**

- Synchronous Rectification for AC-DC/DC-DC converter
- Oring switches
- Power Tools

**• Ordering Information:**

Part NO.	ZMS090N06D
Marking	ZMS090N06
Packing Information	REEL TAPE
Basic ordering unit (pcs)	2500

**• Absolute Maximum Ratings ( $T_C = 25^\circ\text{C}$ )**

Parameter	Symbol	Rating	Unit
Drain-Source Voltage	$V_{DS}$	60	V
Gate-Source Voltage	$V_{GS}$	$\pm 20$	V
Continuous Drain Current	$I_{D@TC=25^\circ\text{C}}$	50	A
	$I_{D@TC=75^\circ\text{C}}$	38	A
	$I_{D@TC=100^\circ\text{C}}$	31.5	A
Pulsed Drain Current <sup>①</sup>	$I_{DM}$	150	A
Total Power Dissipation	$P_{D@TC=25^\circ\text{C}}$	54	W
Total Power Dissipation	$P_{D@TA=25^\circ\text{C}}$	2	W
Operating Junction Temperature	$T_J$	-55 to 150	$^\circ\text{C}$
Storage Temperature	$T_{STG}$	-55 to 150	$^\circ\text{C}$
Single Pulse Avalanche Energy	$E_{AS}$	47	mJ

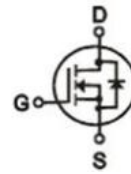
**• Product Summary**

$V_{DS} = 60V$

$R_{DS(ON)} = 9m\Omega$

$I_D = 50A$

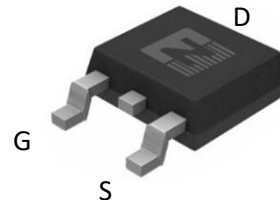

TO-252

**•Thermal resistance**

Parameter	Symbol	Min.	Typ.	Max.	Unit
Thermal resistance, junction - case	$R_{thJC}$	-	-	2.3	°C/W
Thermal resistance, junction - ambient	$R_{thJA}$	-	-	63	°C/W
Soldering temperature, wavesoldering for 10s	$T_{sold}$	-	-	265	°C

**•Electronic Characteristics**

Parameter	Symbol	Condition	Min.	Typ	Max.	Unit
Drain-Source Breakdown Voltage	$BV_{DSS}$	$V_{GS} = 0V, I_D = 250\mu A$	60			V
Gate Threshold Voltage	$V_{GS(TH)}$	$V_{GS} = V_{DS}, I_D = 250\mu A$	1.2		2.5	V
Drain-Source Leakage Current	$I_{DSS}$	$V_{DS} = 60V, V_{GS} = 0V$			1.0	$\mu A$
Gate- Source Leakage Current	$I_{GSS}$	$V_{GS} = \pm 20V, V_{DS} = 0V$			$\pm 100$	nA
Static Drain-source On Resistance	$R_{DS(ON)}$	$V_{GS} = 10V, I_D = 10A$		9	11	m $\Omega$
		$V_{GS} = 4.5V, I_D = 5A$		12	14	m $\Omega$
Forward Transconductance	$g_{FS}$	$V_{DS} = 25V, I_D = 10A$		14		S
Source-drain voltage	$V_{SD}$	$I_S = 10A$			1.28	V

**•Electronic Characteristics**

Parameter	Symbol	Condition	Min.	Typ	Max.	Unit
Gate Resistance	$R_g$	$f = 1MHz$		1.5		$\Omega$
Input capacitance	$C_{iss}$	$f = 1MHz$ $V_{DS} = 25V$	-	960	-	pF
Output capacitance	$C_{oss}$		-	460	-	
Reverse transfer capacitance	$C_{rss}$		-	35	-	

**•Gate Charge characteristics( $T_a = 25^\circ C$ )**

Parameter	Symbol	Condition	Min.	Typ	Max.	Unit
Total gate charge	$Q_g$	$V_{DD} = 25V$	-	14	-	nC
Gate - Source charge	$Q_{gs}$	$I_D = 8A$	-	2.8	-	
Gate - Drain charge	$Q_{gd}$	$V_{GS} = 10V$	-	2.2	-	

Note: ① Pulse Test : Pulse width  $\leq 300\mu s$ , Duty cycle  $\leq 2\%$  ;

Fig.1 Gate-Charge Characteristics

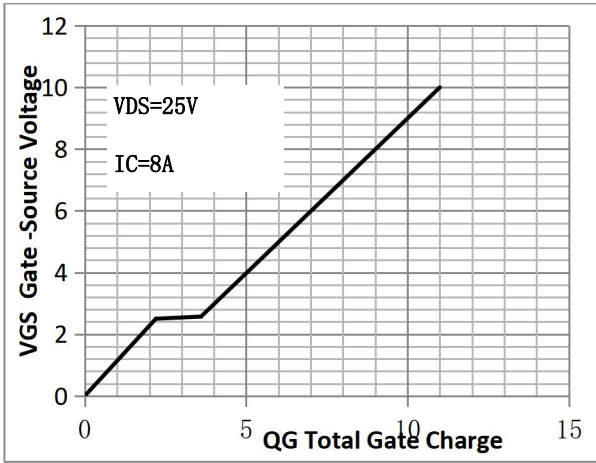

Fig.2 Capacitance Characteristics

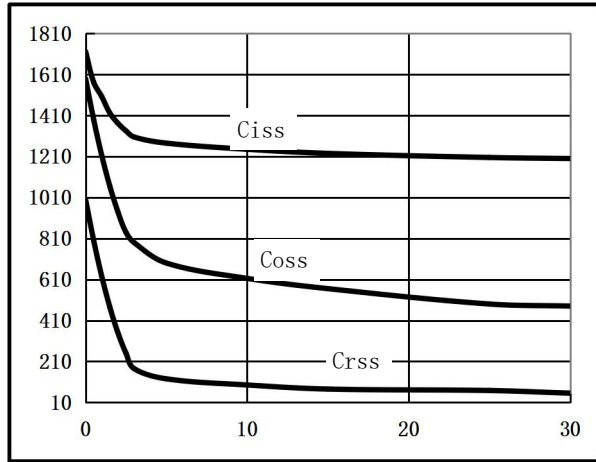

Fig.3 Power Dissipation

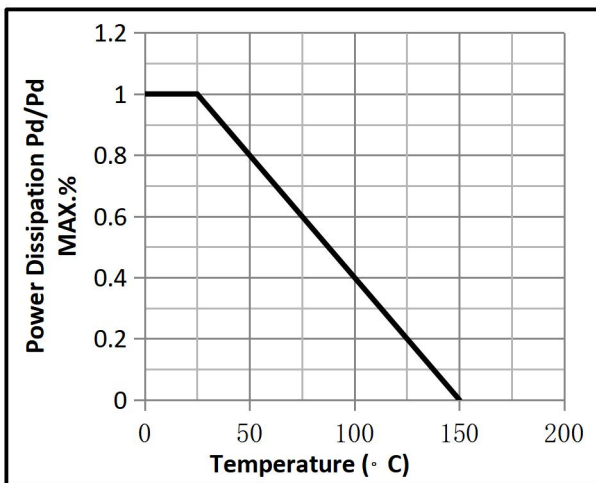

Fig.4 Typical output Characteristics

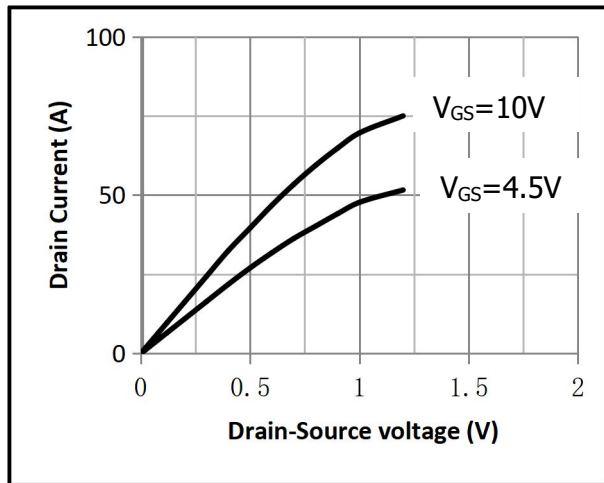

Fig.5 Threshold Voltage V.S Junction Temperature

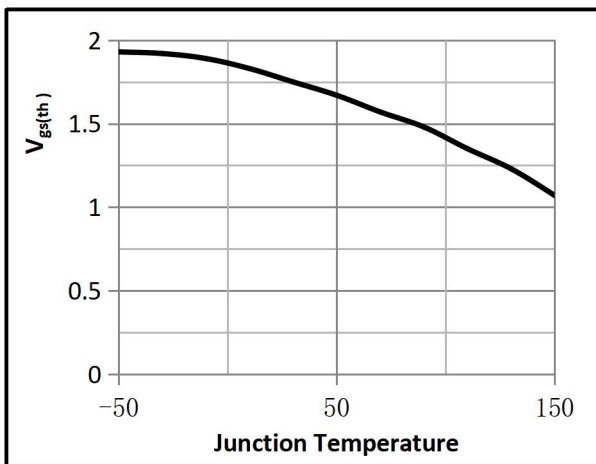

Fig.6 Resistance V.S Drain Current

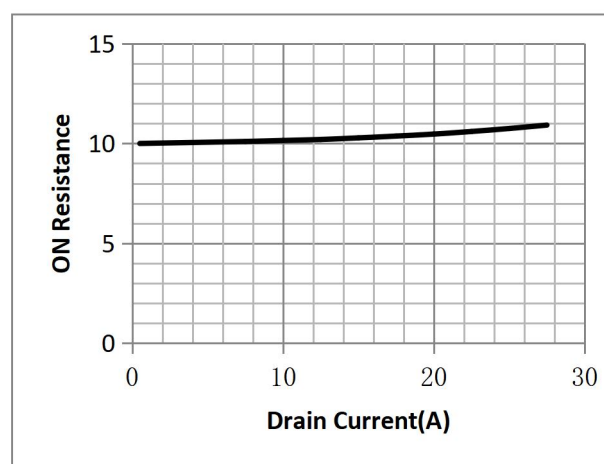

Fig.7 On-Resistance VS Gate Source Voltage

Fig.8 On-Resistance V.S Junction Temperature

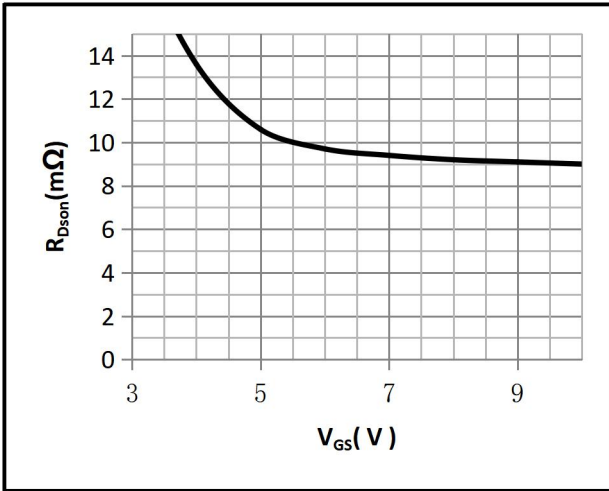

Fig.9 Switching Time Measurement Circuit

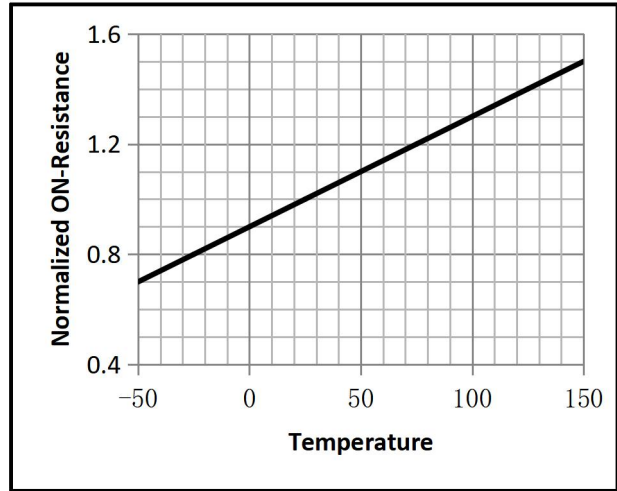

Fig.10 Gate Charge Waveform

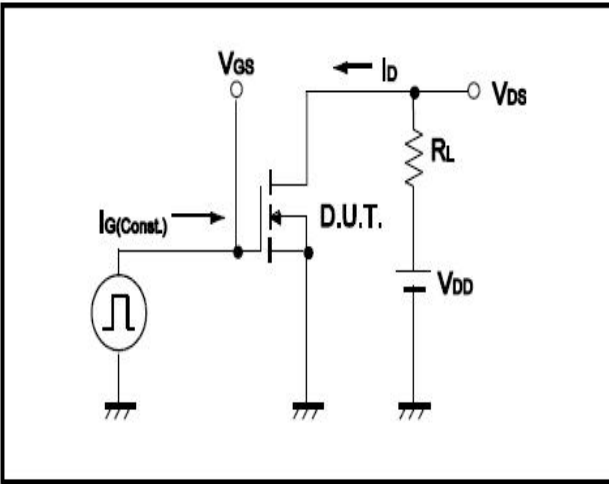

Fig.11 Switching Time Measurement Circuit

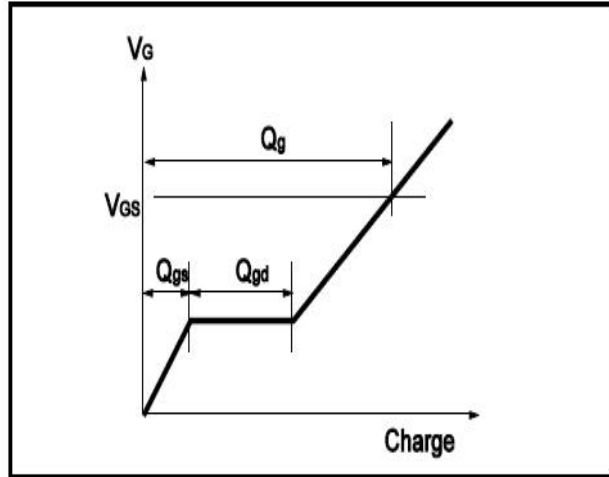
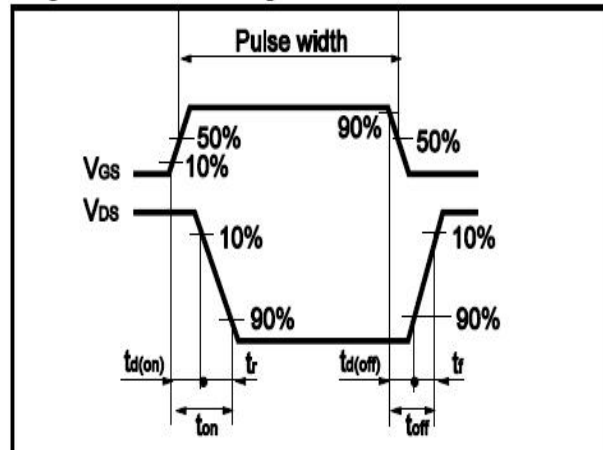
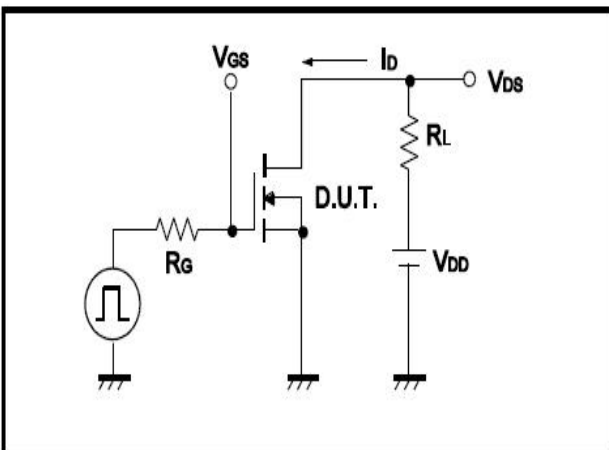

Fig.12 Gate Charge Waveform



•Dimensions(TO-252)

Unit: mm

SYMBOL	min	max	SYMBOL	min	max
A	2.10	2.50	B	0.85	1.25
b	0.50	0.80	b1	0.50	0.90
b2	0.45	0.70	C	0.45	0.70
D	6.30	6.75	D1	5.10	5.50
E	5.30	6.30	e1	2.25	2.35
L1	9.20	10.60	e2	4.45	4.75
L2	0.90	1.75	L3	0.60	1.10
K	0.00	0.23			

